

DESIGN AND FABRICATION OF LOW COST MICROWAVE OSCILLATOR

Suchitav Khadanga and S. Ahmad

Millimeter Wave Devices Laboratory
Central Electronics Engineering Research Institute
Pilani - 333031, India

Abstract:- *A low cost microwave oscillator is fabricated using a RF transistor having a half wave length coaxial line as feedback element. The output impedance is matched with lossless microstrip line and the output is taken across 50Ω load followed by a dc block capacitor. The oscillator is designed by measuring S-parameter of the transistor using a fabricated test fixture and VNA. Software is developed to determine circuit components and dimension of microstrip line, taking transistor S parameter, substrate parameter and operating point as input data. The mask required for the etching the circuit is prepared by using photoplotter. The circuit is fabricated on a low cost double sided copper clad epoxy glass PCB substrate. The power output is about 10 mw at 1.6GHz and band width of 70MHz from NEC transistor.*

1. INTRODUCTION

Oscillators are used as a microwave energy source in all microwave systems such as radar, communications, navigation or electronics warfare. These sources can be termed as dc to microwave signal converters. A typical microwave oscillator consists of an active device such as a diode or transistor and a passive frequency determining element such as a microstrip, cavity resonator, or dielectric resonator for constant frequency oscillators and a varactor or YIG sphere for tuneable oscillators. Before 1960 massive klystron and magnetron tubes were used as microwave sources. Thereafter Gunn and Impatt diodes came in form of solid state microwave oscillators. The extension of the bipolar transistor oscillator to microwave frequencies and development of GaAs MESFET devices in the early 1970 has made available today highly cost affective, miniature, reliable and low noise sources for use right upto millimetre wave frequencies. With the rapid advancement of microwave technology, there has been an increasing need for better performance of oscillators. The emphasises has been on low noise, small size, low cost, high efficiency, high temperature stability and reliability for all oscillators and additionally on wider band widths, better tuning possibility and reduced settling time for tuneable oscillators.

Transistor oscillators are high efficiency sources with low noise. Compared to Gunn oscillators, transistor oscillators do not have the problem of threshold current, heat sinking and the tendency to lock at spurious frequencies. Transistor oscillators can be realised using either bipolar transistor or GaAs FET devices. Bipolar oscillators have maximum oscillation frequency, lower than that of GaAs FET. While the former is nosier than the later. FETs are used for microwave applications such as low noise, high gain amplifications above 4 GHz. But in the field of power applications FETs have not replaced silicon BJTs below 4GHz. Since they have not able to deliver power levels high enough in class B or class C and pulsed power applications. As our desired frequency of operation is below 4 GHz, so we take silicon BJT to design our circuit. The design and fabrication of microwave oscillator using bipolar transistor have been explained in this paper.

2. MICROWAVE TRANSISTOR OSCILLATOR

Microwave transistor oscillators having power output up to several hundred milliwatts have become important components in microwave communications and test systems. Microwave transistors are rapidly replacing electron tubes as fundamental frequency

signal sources and local oscillators at L and S band frequencies. Such transistors are also available for frequency doubler oscillators and fundamental frequency oscillators that drive frequency multipliers in C and X band power sources. Low level transistor signal sources that feature low residual FM noise, good frequency stability and phase locking are currently being produced at relatively low cost. These sources which are very competitive with newer diodes and bulk devices, are available in a wide range of options from a growing number of commercial suppliers.

In selecting a transistor for power oscillator, the circuit designer should realise that any transistor capable of power amplification is also suitable for power oscillation. These are very similar to those of a class-C transistor power amplifier. In each case the transistor must provide power at the desired operating frequency. The major difference is that the oscillator must include a feedback network that couples a portion of the power output back to the input section. The oscillator power delivered to the load is the equivalent amplifier power output less than the amount of power back to the input circuit and any power loss in the feedback network. In the design of an oscillator circuit, therefore the approach used can be very similar to that employed in the design of an amplifier but that must be extended to include the design of the required feedback network.

The choice of the proper transistor and the optimum circuit configuration for a transistor microwave oscillator are largely determined by the circuit power output and efficiency required over the frequency range of interest. Generally these requirements are similar to those necessary for good amplifier performance. These can be found out in commercial data books. Accordingly device is selected and used for oscillator.

3. MICROWAVE OSCILLATOR DESIGN

A microwave oscillator is a half wavelength coaxial line loaded by the input impedance of the transistor at one end and the transistor output impedance at the other end. In the output port $\lambda/8$ line is used to match the output reactance of the transistor and $\lambda/4$ line is used to match output resistance to 50Ω load. The output will be taken across 50Ω load followed by dc block capacitor.

For the transistor configuration usually common-base or common gate configuration is selected for the design of the oscillator, because of low input impedance of the CB/CG configuration which makes it easy to match the feedback line.

The purpose of microstrip line is to cancel out the output impedance. The characteristic impedance of the microstrip line can be calculated by using the S parameter of the transistor. Let the S parameter of the transistor are S_{11} S_{12} S_{21} S_{22} . The input (Z_{1e}) and output (Z_{2e}) impedances for common emitter configuration are given by the following relations,

$$Z_{1e} = \frac{1 + S_{11}}{1 - S_{11}}, \quad (1)$$

$$Z_{2e} = \frac{1 + S_{22}}{1 - S_{22}}. \quad (2)$$

Due to low output impedance of common base configuration, it is easy to match with the load and, thus, this configuration is chosen for oscillator design. For this purpose, common emitter impedances are converted to common base configuration as follows[1]:

$$Z_{1b} \cong \frac{z_{1e}}{|S_{21}|}, \quad (3)$$

$$z_{2b} = \text{Re } z_{2e} \cdot |S_{21}| \parallel \text{Im } z_{2e} \parallel. \quad (4)$$

Where z_{1b} and z_{2b} are Common base input and output impedance respectively.

The output reactance of the transistor $\text{Im}(z_{2b})$ is matched with $\lambda/8$ line. The remaining resistance $\text{Re}(z_{2b})$ is transformed to 50Ω load with a $\lambda/4$ line.

4. BARK-HAUSEN CONDITION

In order to get sustained oscillation, the circuit should satisfy Bark-hausen condition of sustained oscillation. This says that the feedback voltage gain product should be greater than or equal to one and the feedback signal should be in phase. This is expressed as

$$f \times A_v \geq 1, \quad (5)$$

where A_v - effective voltage gain and f - feedback factor.

The feedback factor is the magnitude of the transmission coefficient of the 50 ohm coaxial feedback line defined as,

$$f = |t| = \frac{|t_{12}| |t_{23}|}{|1 - r_{23} * r_{21}|} \quad (6)$$

Where t_{12} , t_{23} , r_{12} and r_{23} are transmission and reflection coefficients across output/feedback line, feedback line/input of the transistor and feedback line respectively. These are written as,

$$r_{21} = \frac{\text{Re}(Z_{2b}) - 50}{\text{Re}(Z_{2b}) + 50}, \quad (7)$$

$$r_{23} = \frac{Z_{1b} - 50}{Z_{1b} + 50}, \quad (8)$$

$$|t_{12}|^2 = 1 - |r_{12}|^2 = 1 - |r_{21}|^2, \quad (9)$$

$$\text{and } |t_{23}|^2 = 1 - |r_{23}|^2 \quad (10)$$

The current gain of a transistor for common base configuration is approximately unity. Therefore the effective voltage gain is given as [1].

$$A_v = \frac{A_i * r_2}{r_1} \quad (11)$$

Besides the Quality factor is given by the following expression [1].

$$Q = \frac{2\pi(1 + |r_{23}|^2)}{1 - |r_{23}|^2 + (1 - |r_{21}|^2)|r_{23}|^2} \quad (12)$$

The half wave length feedback line can be regarded as resonant tank circuit. The standing waves on the line play the role of circulating currents and fields in an LC tank circuit. At resonance there is a phase delay of 90° in the transmitted wave. There is a phase delay of 180° due to propagation delay through the half wave length line. Since the operating frequency will be somewhat higher than the resonant frequency, there will be an additional phase delay of almost 90° . So in total there is a phase delay of almost 360° , and it looks the Bark-hausen phase condition is satisfied.

5. DESIGN OF MICROSTRIP LINE

The characteristic impedance of microstrip line can be found from the empirical formulae [1], $Z_C = \frac{377}{\sqrt{\epsilon_r} \left(\frac{W}{T} \right) \left[1 + 1.735 \left(\frac{W}{T} \right)^{-0.836} \right]}$

Where Z_C is the Characteristic impedance of microstrip line in Ω , ϵ_r is the relative permittivity of dielectric medium and W/T is the width to thickness ratio of microstrip line.

By solving this equation a graph is plotted between characteristic impedance and width to thickness ratio of the microstrip line. From the graph the required W/T ratio of the required characteristic impedance is to be found out. From which the width of microstrip line is found out. The length is given by the following relation[1],

$$L = \lambda_0 \times \left[1 + 0.63(\epsilon_r - 1) \left(\frac{W}{T} \right)^{0.123} \right]^{-1/2},$$

The operating wave length is expressed as $\lambda_0 = C/f_0$ with operating frequency f_0 and light velocity C .

6. EXPERIMENTAL

Following experiments are carried out in the Millimeter wave devices laboratory.

6.1. S-parameter measurement

The S-parameters of the transistor are measured using vector network analyser (VNA) and fabricated test fixture. For transistor NE73435 S-parameters are measured at different frequencies under various operating conditions are listed in table 1.

TABLE 1: S parameter of the transistor NE734355

FOR $V_{ce}=5V, I_c=10mA$.

FREQUENCY (GHz)	S_{11}		S_{21}		S_{12}		S_{22}	
	MAG.	ANG.	MAG.	ANG.	MAG.	ANG.	MAG.	ANG.
1	0.601	-154	2.5	74.4	0.089	30.0	0.612	-39.0
1.5	0.607	-175	1.71	56.0	0.095	32.2	0.612	-50.0
2	0.610	172	1.317	39.0	0.107	32.3	0.616	-62.0
2.5	0.613	160	1.071	25.3	0.118	34.0	0.632	-74.0

FOR $V_{ce}=10V, I_c=10mA$

FREQUENCY (GHz)	S_{11}		S_{21}		S_{12}		S_{22}	
	MAG.	ANG.	MAG.	ANG.	MAG.	ANG.	MAG.	ANG.
1	0.603	-167	2.78	71	0.073	37	0.563	-37
1.5	0.605	178	1.893	54	0.088	39	0.572	-48
2	0.613	167	1.442	37	0.102	39	0.583	-61
2.5	0.621	156	1.161	25	0.117	40	0.664	-73

FOR $V_{ce}=20V, I_c=10mA$

FREQUENCY (GHz)	S_{11}		S_{21}		S_{12}		S_{22}	
	MAG.	ANG.	MAG.	ANG.	MAG.	ANG.	MAG.	ANG.
1	0.607	-176	3.063	67.1	0.061	47.0	0.521	-34.0
1.5	0.621	172	2.039	51.0	0.080	49.0	0.541	-46.0
2	0.633	161	1.532	36	0.096	49.2	0.560	-58.0
2.5	0.646	152	1.220	22.4	0.112	49.3	0.590	-71.0

6.2. Oscillator circuit design

For the design of the oscillator circuit, we are taking the parameters at the frequency 2GHz for $V_{ce}=10V$ and $I_c=10mA$ (table 1)

$$Z_{1b} = 8.43 + j 3.96$$

$$Z_{2b} = 55.8 - j 66$$

$$Q = 9.53.$$

For this transistor NE73435 at the frequency of 2GHz it is calculated that f_{Av} is 3.83, than one. So the oscillator circuit satisfies the Barkhausen condition for sustained oscillation.

The circuit diagram of the oscillator circuit is shown in the figure 1

Where:

Transistor : NPN Silicon NE73435 from NEC.

$$R_E = 2.2K\Omega, R_C = 1K\Omega, C_1 = 100pF$$

$$C_2 = 2PF, C_3 = 100PF, C_4 = 2PF$$

L_1, L_3 - Radio frequency coil.

$L_2 = Co$ axial line (half wavelength) of miniature diameter , length = 5cm.

$L_4, L_5 = \lambda/4$ and $\lambda/8$ microstrip line of characteristic impedance 55.8Ω and 66Ω respectively.

The oscillator circuit is fabricated on 1.58mm thick double sided copper clad printed circuit board of epoxy glass substrate.

6.3. Artwork for mask

The layout of the oscillator is shown in figure_2. It has been prepared by photoplotter

6.4. Fabrication of the circuit

The circuit is fabricated on a epoxy glass PCB. Since the metallisation is copper, we use $FeCl_3$ etchant to etch the substrate. The RFCs are made from 6 turns of SWG 33 copper wire 5 mm diameter. The purpose of RFCs are to block the microwave energy to the bias supply. The chip capacitors used in the circuit are from Johnson company. General purpose resistors has been used. All these components along with transistor are soldered to the PCB whose dimension is 1.5"x 1". The circuit is mounted in a aluminium box. The purpose of aluminium box is to prevent microwave loss during characterisation of the circuit. The bias to the transistor is supplied by external power supply. The output is taken through SMA connector, which is fixed to the wall of the box.

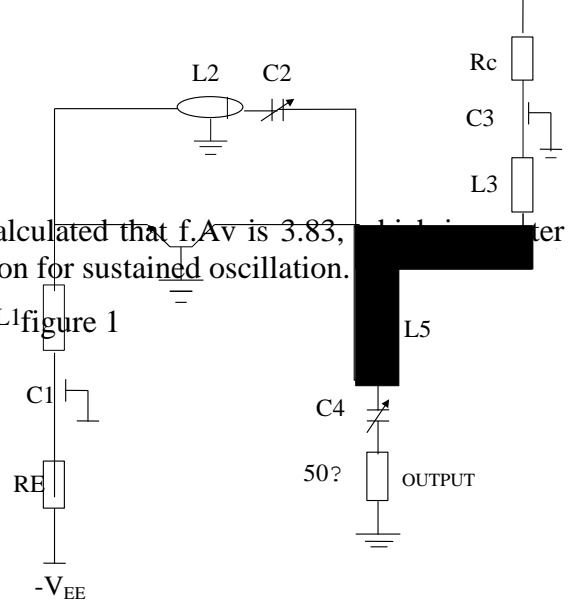

Figure 1 : microwave transistor oscillator using NE73435.



Fig 2: layout of the oscillator

7. RESULTS AND DISCUSSION

The oscillator circuit is characterised by spectrum analyser and power meter. The performances of the oscillator are shown in figure (3), (4) and (5). Power output of 11 dBm at frequency 1.6 GHz and band width of 67 MHz is obtained for applied bias at 30V . The frequency of the oscillator is tuneable by using a tuning capacitor in the feedback circuit.

The measurement of power to a better precision value can be done by use of directional coupler and power meter. The graph between Vcc and power output is shown in figure (6). It agrees with the frequency v/s gain curve given in the data book. However the power output can further be increased by using substrate having less dissipation factor. So a substrate having less dissipation factor can be used to get more power. But this will increase the cost ultimately.

9. CONCLUSION

A low cost microwave oscillator is designed and fabricated on epoxy glass PCB. 12.5 mw power output is obtained. The power output can be increased by using substrate having less dissipation factor. But this will increase the cost. The performance is noted to be satisfactory.

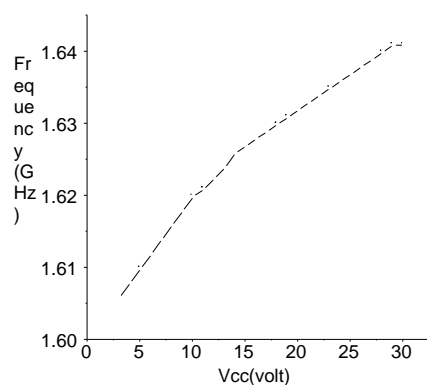

Fig.3: Variation of Frequency with collector supply.

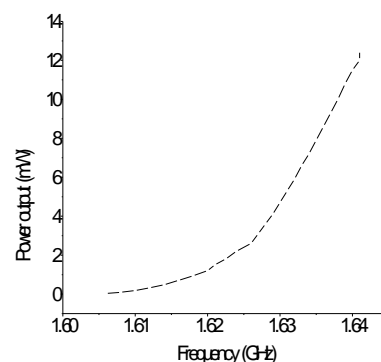

Fig. 4: Variation of Power output with frequency.

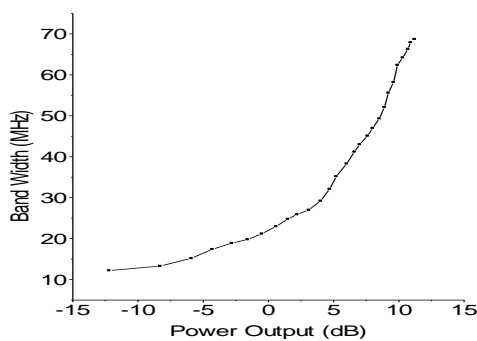

Fig.5: Variation of band width with power output in accordance with frequency as shown in fig 4.

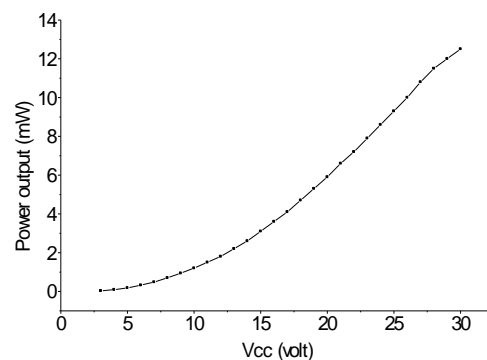

Fig.6: Variation of Power output with collector supply.

References:

1. Arther, F., 'Microwave and fiber optics communications', Prentice Hall, New Jersey.
 2. Gentili, Christian, 'Microwave amplifiers and oscillators', North Oxford Academic, London.
 3. Chang, Kai., 'Microwave solid state circuits and applications', Wiley, New York.
 4. Gonzalez, G., 'Microwave transistor amplifiers', Prentice Hall, New Jersey.
 5. Bahl. I and Bhartia. P, 'Microwave solid state circuit design', Wiley, New York.
- [31]Akbarzhon Madaminov, "Recommendation Systems", Engpaper Journal
- [32]Aathi oli.S , "REVIEW PAPER ON PHISHING ATTACKS", Engpaper Journal
- [33]Rania Fernando, "IoT based – Street Light Controlling System", Engpaper Journal
- [34]K. SAI BHARGAV, V. RAJENDRA, "Study on Data Structures for Machine Learning", Engpaper Journal
- [35]Brundha P, Guruprasad K N, Amith V Hiremath,Sirisha R, Chandrakanth G Pujari , "Face Detection Based Smart Attendance System Using Haar Cascade Algorithm", Engpaper Journal
- [36]Afsana Nadaf , "RFID BASED LIBRARY MANAGEMENT SYSTEM", Engpaper Journal
- [37]Mr. Vedant Thube, Neha Thakur, Mr. Siddhesh Balsaraf,Ms. Priyanka Hanchate, Dr. S. D. Sawarkar , "Accident Prevention using Eye Drowsiness & Yawning Detection", Engpaper Journal
- [38]Abhishek A Hishobkar, Rutuja Gaonkar, Jagdish Chintamani , "DIGITAL DIARY", Engpaper Journal
- [39]Pooman Suryavanshi, Aryan Ghadge, Manali Kharat , "TAXI SERVICE for VISUALLY IMPAIRED", Engpaper Journal
- [40]Mr. Pankaj yadav, Shila Jawale, Mr. Ashutosh Mahadik, Ms. Neha Nivalkar, Dr. S. D. Sawarkar , "NEWS ARTICLES CLASSIFICATION", Engpaper Journal
- [41]Rahul Chavan, Manvee Bhoir, Gaurav Sapkale, Anita Mhatre, "Smart Tourist Guide System", Engpaper Journal
- [42]Rutik Desai, Akash Jadhav,Suraj Sawant ,Neha Thakur , "Accident Detection Using ML and AI Techniques", Engpaper Journal
- [43]Anagha Vishe,Akash Shirsath, Sayali Gujar, Neha Thakur , "Student Attendance System using Face Recognition", Engpaper Journal
- [44]Ms.Sayali Patekar, Shila jawale, Ms.Pranali Kurhade, Mr.Shubham Khamkar , "Smart Classroom Application", Engpaper Journal
- [45]DOSHI SAKSHI, DEVYANI CHAUDHARI, POOJA GAIKWAD, RUTUJA CHABUKSWAR,MRS. SUJATA KOLHE, "TOURISM SIMPLIFIED THROUGH VOICE", Engpaper Journal
- [46]Afreen Fathima,Samreen Jameel, Pathan Ahmed khan , "ACCIDENT DETECTION AND ALERTING SYSTEM", Engpaper Journal
- [47]Suman Zareen, Tuba Masood, Pathan Ahmed khan, "E-Commerce Web Application with Augmented Reality", Engpaper Journal
- [48]Lok Shan CHAN, "Selection of Waterfall and Agile Methodologies in Software Testing", Engpaper Journal
- [49]Barve Rutu, "CLOUD COMPUTING SYSTEM FOR GAMING", Engpaper Journal
- [50]Harshvardhan Singh, "Machine Learning: Fake News Blocking", Engpaper Journal
- [51]M.Al Batahari, "SERVERS ROOM MONITORING SYSTEM USING IOT", Engpaper Journal

- [52]AYUSHI ANKITA RAKSHIT, “VIRTUAL MASTER USING PYTHON”, Engpaper Journal
- [53]Baldeep Kaur, “REAL TIME SLEEP DROWSINESS DETECTION USING FACE RECOGNITION”, Engpaper Journal
- [54]Suchitav Khadanga, “Two Stage CMOS Operational Amplifier From Specification to Design”, Engpaper Journal
- [55]nidhi sharma, “Introduction to Remote Sensing”, Engpaper Journal
- [56]Rohith N Reddy, “COVID-19 Detection using SVM Classifier”, Engpaper Journal
- [57]Swapnil Kole, “COVID-19 Database on Consortium Blockchain”, Engpaper Journal
- [58]TejalLengare, PallaviSonawane, PrachiGunjal, ShubhamDhire, Prof.Shaikh.J.N , “Accident Detection & Avoidance System in Vehicles”, Engpaper Journal
- [59]Abhishek Pawshekar, Deepti More, Akash Khade, Pratiksha Wagh, Ganesh Ubale, “Augmented Reality: to converting and placing object into 3D model”, Engpaper Journal
- [61]Prof.Ubale.G.S, Pranjal Adhav,Pooja Gaikwad, Sushama Nadavade ,Pooja Kale , “Iot based Bridge Monitoring System”, Engpaper Journal
- [62]Divya Deewan, Priyanka Maheshwari, Sanjay Jain, “A REVIEW OF BATTERY-SUPERCAPACITOR HYBRID ENERGY STORAGE SYSTEM SCHEMES FOR POWER SYSTEM APPLICATION”, Engpaper Journal
- [63]Prof.Ansari.M.B, Pranjal Adhav,Pooja Gaikwad,Sushama Nadavade,Pooja Kale, “Survey on MyHelper IOT based Bridge Monitoring System”, Engpaper Journal
- [64]Shreyas.S.J, Saddam hussain, Chaithra E, “COMPARATIVE STUDY ON SEISMIC RESPONSE OF MASONRY INFILLED RC FRAME BUILDINGS AND MIVAN BUILDINGS WITH DIFFERENT PERCENTAGE OF WALL OPENINGS”, Engpaper Journal
- [65]Yusuf Ali Hassan, “Somali Power-Grid Significant Challenges”, Engpaper Journal
- [66]Ahmed N. Elhefnawy, “Refractive IR Objective Optical Design Operating in LWIR band For Military Observation Applications”, Engpaper Journal
- [67]S MANJULA, D SELVATHI and SUCHITAV KHADANGA, “Design of low-power CMOS transceiver front end for 2.4-GHz WPAN applications”, Engpaper Journal
- [68]Suchitav Khadanga, “Fabrication of MEMS Pressure Sensor on thin film membrane”, Engpaper Journal
- [69]Suchitav Khadanga and Dr. K.R.Suresh Nair, “An Introduction to Bluetooth”, Engpaper Journal
- [70]Suchitav Khadanga and S. Ahmad, “DESIGN AND FABRICATION OF LOW COST MICROWAVE OSCILLATOR”, Engpaper Journal
- [71]Ameen Ahmed, Noushad S, Suchitav Khadanga, K.R.Suresh Nair, P.K.Radhakrishnan, “DEVELOPMENT OF LOW PHASE NOISE SMALL FOOT PRINT SURFACE MOUNT VOLTAGE CONTROLLED OSCILLATOR”, Engpaper Journal
- [72]Suchitav Khadanga , “Synchronous programmable divider design for PLL Using 0.18 um cmos technology”, Engpaper Journal
- [73]Kavya.G.R, Shivaraju.G.D, Dr. T V Mallesh, S R Ramesh, “PROGRESSIVE COLLAPSE RESISTANCE OF FLAT SLAB BUILDING”, Engpaper Journal



<https://www.engpaper.com>